

MTSFB TR 004:2019



TECHNICAL REPORT

**IOT-BASED PADDY PRODUCTIVITY MONITORING
AND ADVISORY SYSTEM (E-PADI)**

Preface

Malaysian Technical Standards Forum Bhd (MTSFB) has awarded Universiti Malaysia Perlis (UniMAP) the Industry Promotion and Development Grant to implement the Proof of Concept (PoC) through the IoT-Based Paddy Productivity Monitoring and Advisory System (E-Padi). The duration of this PoC lasts for a period of 9 months starting January 2018.

The PoC is done at Batu 19, Kampung Sena, Kuala Nerang, Kedah. The key objective of this PoC is to provide the monitoring and advisory information system to the farmers which include the main paddy development variables i.e. soil pH, water level and soil nutrients in paddy fields.

This Technical Report outlines the objective, benefit, the scope of work, methodology and result analysis.

Prepared by:

School of Microelectronic Engineering, Universiti Malaysia Perlis (UniMAP)



In collaboration with:

MASDAR Agro and Jabatan Pertanian Padang Terap, Kedah Darul Aman



Published by:

Malaysian Technical Standards Forum Bhd (MTSFB)
Malaysian Communications and Multimedia Commission (MCMC)
Off Persiaran Multimedia, Jalan Impact, Cyber 6
63000 Cyberjaya, Selangor Darul Ehsan
Tel : (+603) 8320 0300
Fax : (+603) 8322 0115
Email : admin@mtsfb.org.my
Website : www.mtsfb.org.my

Contents

	Page
Abbreviations	ii
1. Introduction	1
2. Target groups and benefits.....	1
2.1 Target Group	1
2.2 Benefits.....	1
3. Objectives	2
4. Scope of work	2
5. Methodology	2
5.1 Overview of the e-PADI system	2
5.2 System architecture.....	3
5.3 Sensor nodes	5
5.4 Gateway (GW) unit.....	6
5.5 monitoring dashboard	8
6. Result analysis.....	9
6.1 Sensor nodes and user application.....	9
6.2 Gateway (GW) unit.....	9
6.3 Continuous analysis mode	10
7. Conclusion	11
Annex A List of sensors	12
Annex B List of gateways	14
Annex C List of management	16
References.....	17

MTSFB TR 004:2019

Abbreviations

API	Application Programming Interface
EC	Electrical Conductivity
GW	Gateway
GPRS	General Packet Radio Service
GPS	Global Positioning System
HTTP	Hyper Text Transfer Protocol
ICT	Information and Communication Technology
IoT	Internet of Things
IP	Internet Protocol
LCC	Leaf Colour Chart
LCD	Liquid Crystal Display
LoRa	Long Range
LoRaWAN	Long Range Wide Area Network
LR-WPAN	Low-Rate Wireless Personal Area Network
MCU	Microcontroller Unit
SoC	System on Chip
TCP	Transfer Control Protocol
TCP/IP	Transmission Control Protocol/Internet Protocol
UNIMAP	Universiti Malaysia Perlis
UV	Ultra Violet
WiFi	Wireless Fidelity
Wiskar	Wireless Sensor Knowledge Archive
WSN	Wireless Sensor Network

IOT-BASED PADDY PRODUCTIVITY MONITORING AND ADVISORY SYSTEM (E-PADI)

1. Introduction

The e-PADI system targets to facilitate farmers to monitor paddy development through its real-time wireless sensor nodes. These include measurement of soil acidity, water level and soil nutrients in the paddy field using a user's dashboard system on a smartphone. The e-PADI dashboard application software gives advisory notification to farmers during paddy development stages. In addition, the system is supported by a data backup system which allows for data recording for further analysis by farmers or authorities. In order to increase the paddy productivity in Malaysia, UNIMAP has come out with the initiative to develop a cost-effective project through an IoT-based paddy productivity monitoring and advisory system called e-PADI system.

2. Target groups and benefits

2.1 Target Group

The solution is developed focusing on the paddy farmer but it may be extended to other groups of people that will be using the system such as follows:

- a) plantation companies;
- b) gardeners;
- c) government agencies related to agriculture; and
- d) researchers.

2.2 Benefits

This solution provides benefits to the farmers as well as to the other target groups which are:

- a) provide options to migrate from conventional monitoring into smart paddy monitoring system;
- b) to improve the monitoring technique through the real-time monitoring system; and
- c) to receive the accurate advisory information which may help the farmer to take necessary action to their paddy field for better productivity.

3. Objectives

The objectives of the project are as follows:

- a) to design and develop an IoT-based paddy monitoring and advisory system;
- b) to enhance the conventional lab-based and human-based paddy monitoring system;
- c) to test and implement the system in a paddy field to increase paddy productivity; and
- d) to analyse crucial paddy environment parameters to enhance paddy productivity.

4. Scope of work

The scope of work for this project is to develop an IoT-based e-PADI system that is able to continuously monitor paddy productivity variables through the implementation of IoT technology which includes the 3 following processes:

- a) design and integrate the hardware and software for IoT-based paddy monitoring and advisory system

This process involves the development of 3 main elements which are sensor nodes, Gateway (GW) system and user application software.

- b) store and retrieve data from hardware to cloud

Data retrieved from the sensor nodes will be stored to the Thingspeak cloud using the HyperText Transfer Protocol (HTTP) protocol over the internet.

- c) perform system testing and calibration and deploy project implementation in the paddy field

The developed system will be tested and calibrated against the existing conventional lab-based soil pH measurements.

5. Methodology

5.1 Overview of the e-PADI system

The main variables for paddy cultivation are water level, soil acidity and nutrients as shown in Figure 1. Conventionally, the Nitrogen fertilizer is measured manually using the Leaf Colour Chart (LCC) as in Figure 1c. However, through the e-PADI system, it helps the farmers managing their paddy cultivation effectively through IoT technology. It was designed to monitor paddy at various development stages, beginning from vegetative until the harvesting stage.

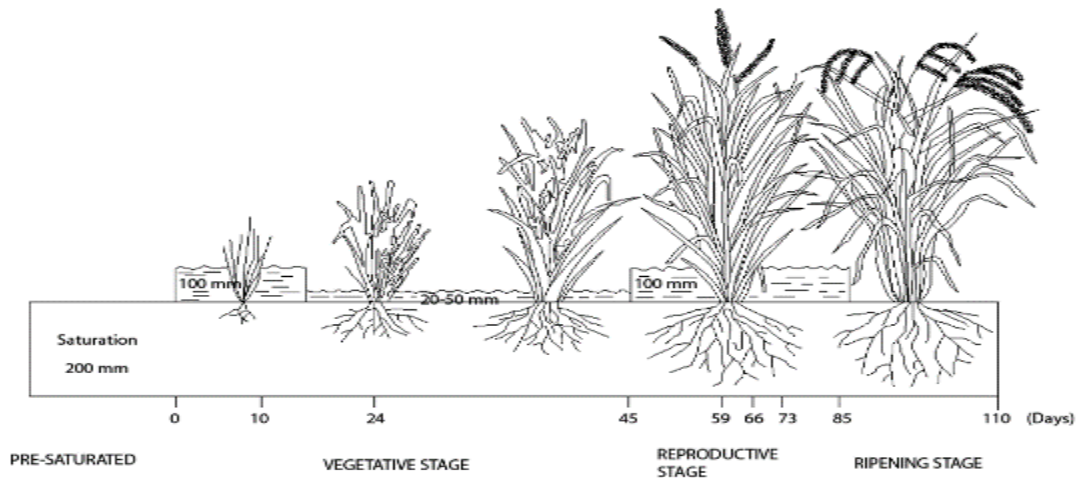

Figure 1.a Water level for different paddy development stage

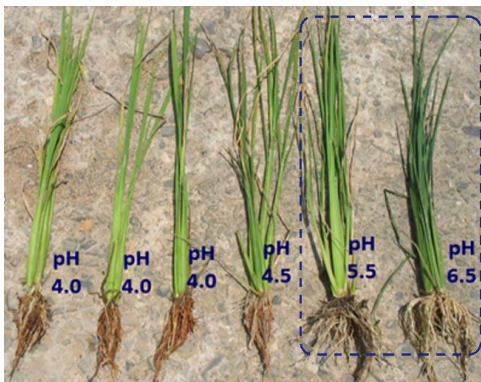

Figure 1.b Paddy soil acidity

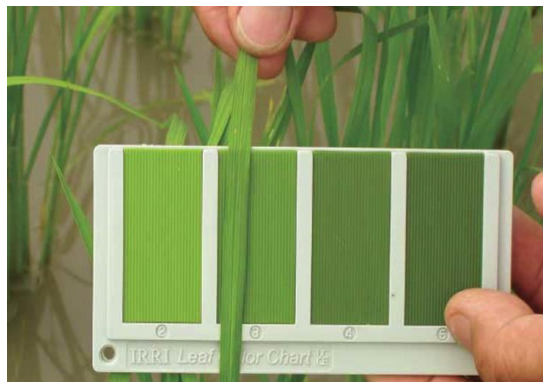

Figure 1.c Leaf Colour Chart (LCC)

Figure 1. Main variables for paddy development

5.2 System architecture

The e-PADI system architecture as in Figure 2 comprises of 3 elements as follows:

- a) sensor nodes;
- b) GW unit; and
- c) application (monitoring dashboard).

For an open space area, the sensor nodes can be placed at a maximum distance of a 13 km radius away from the GW unit. The sensor node reads variables in the paddy field and transmits the measured data to the GW unit via Long Range (LoRa) transceiver. Then, the GW unit pushes the data received from each sensor node to the ThingSpeak cloud server. Upon successful uploading the data, all measured variables from the testing site can be viewed via a built-in customisable e-PADI dashboard. ThingSpeak offers features that enable a user to analyse measured variables in the paddy field using graphs and raw data for further analysis as well as for data backup for prediction.

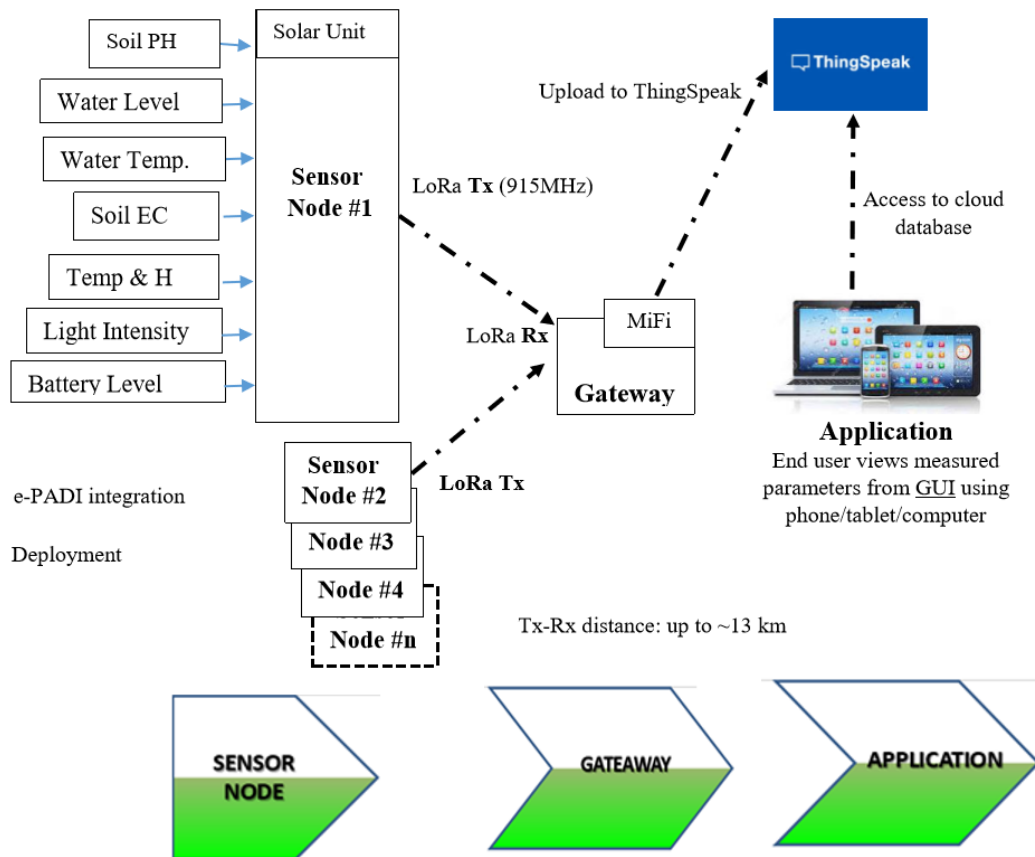

Figure 2. The architecture of the e-PADI system

Detail specifications of the e-PADI system is summarised in Table 2.

Table 2. Specification of the e-PADI system

Item	Specification
Operating Voltage	5 Vdc
Processor operating frequency	16 MHz
Power consumption (e-PADI)	~ 1 W
Measured variables	a) soil pH b) water level c) water temperature d) soil Electrical Conductivity (EC) e) system temperature and humidity (H) f) light intensity g) battery level h) plantation date and paddy age i) date to harvest

Table 2. Specification of the e-PADI system (continued)

Item	Specification
Maximum measuring range (GW-sensor node)	8 km to 13 km
LoRa frequency band	915 MHz (900 MHz - 931 MHz)
Communication topology	Star network

5.3 Sensor nodes

The e-PADI sensor nodes as in Figure 3 is able to monitor paddy development variables continuously in real-time. The system is solar-powered and able to measure 7 parameters as follows:

- a) soil pH sensor;
- b) ultrasonic range sensor;
- c) soil EC sensor;
- d) water temperature sensor;
- e) ambient temperature sensor;
- f) humidity sensor; and
- g) lux meter.



Figure 3. The e-PADI sensor node

The heart of the sensor node is Arduino Nano with an ATmega328P microcontroller unit as its main controller. The microcontroller collected various data through the sensors in the paddy field. Data from sensor nodes are combined in a form of string data type which is transmitted to the GW unit using LoRa wireless transceiver. Details of the sensor node's operational flow are illustrated in Figure 4. The description of the sensors used in the e-PADI system is summarised in Annex A.

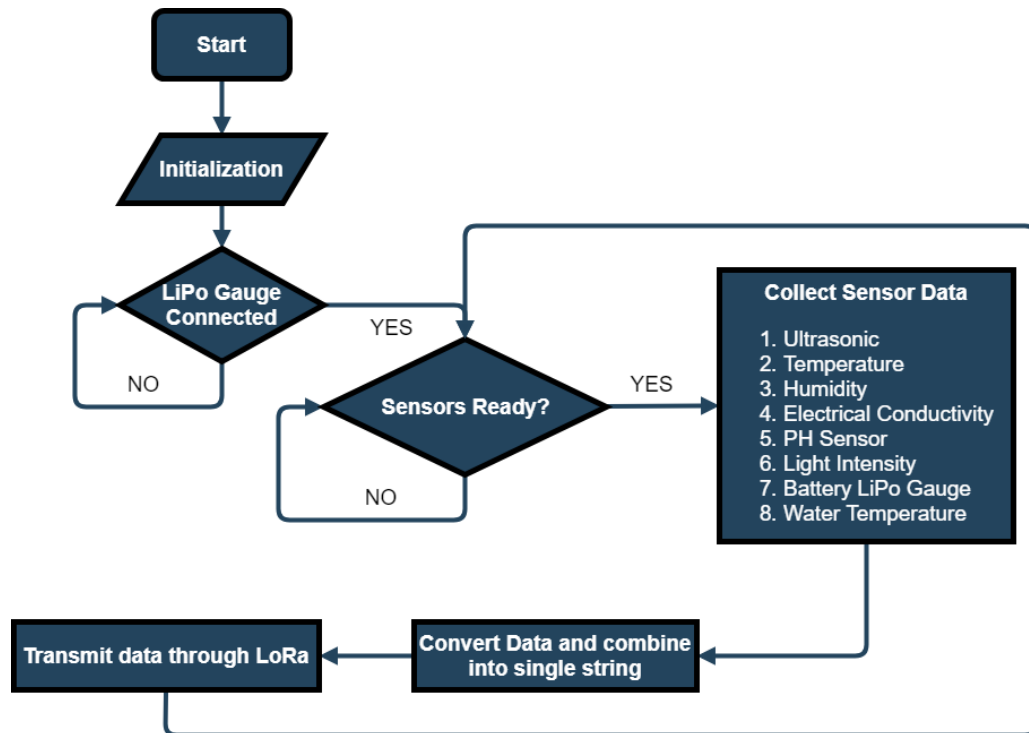

Figure 4. Sensor node operation flow

5.4 GW unit

Communication between multiple nodes in the paddy field to the GW unit is established using star network topology. In the developed system, LoRa transceiver in the GW unit collects measured paddy variables from sensor nodes sequentially. This wireless communication topology reduces the risk of data collision during data transfer.

In an open space area, LoRa transceiver in the sensor node can transmit data to the GW unit with a maximum distance of 13 km radius, which is sufficient for most long-range IoT applications including the e-PADI system. The GW unit comprises of 2 microcontrollers as follows:

- a) application microcontroller; and
- b) client microcontroller.

The main task of the application microcontroller is to collect data from each of the sensor nodes, combine the data then transmit the packet data to the client microcontroller via serial communication. For the next cycle of data collection, the application processor waits for the client processor to send a ready signal. This cycle continues as the system running.

The simplified operational flow diagram of the application microcontroller in the GW unit is illustrated in Figure 5.

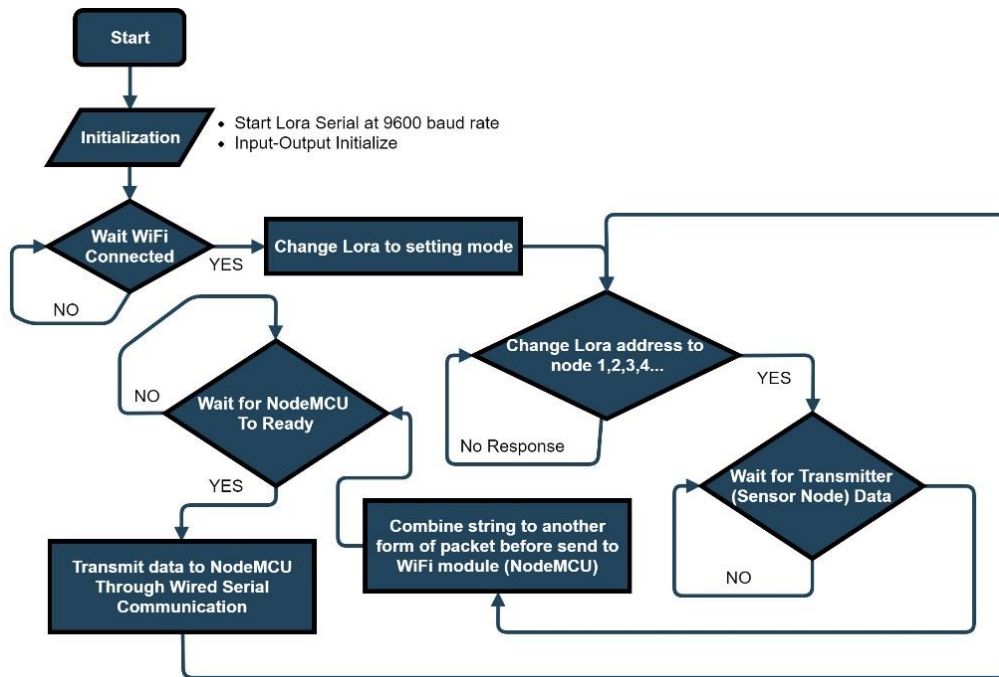

Figure 5. Simplified operational flow of the application processor

The combined data collected from sensor nodes in the paddy field are transmitted using a data packet to the client microcontroller (the ESP8266) via the serial interface. The client microcontroller is a 32-bit System on Chip (SoC) Wireless Fidelity (WiFi) module with an integrated Transmission Control Protocol/Internet Protocol (TCP/IP) protocol stack that provides the GW system access to an available WiFi network. Once the client microcontroller is connected to the internet, the LoRa address which dictates by the sensor nodes address as in Figure 5 will be changed to the next LoRa address.

The client processor plays an important role in the e-PADI system. It is responsible to upload data collected from the application processor to the cloud server. The cloud database connection and data transmission status will be displayed on the GW Liquid Crystal Display (LCD) screen.

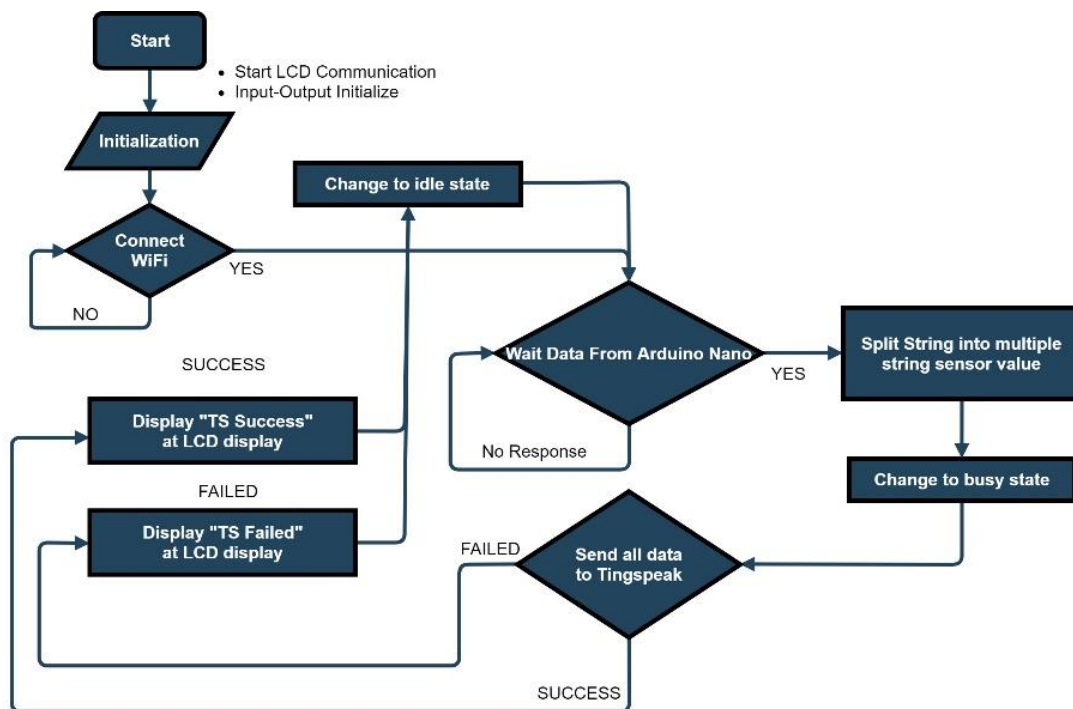

Figure 6. The simplified operational flow of the client processor with its display unit in the GW

ThingSpeak is an open-source of IoT application and Application Programming Interface (API) which store and retrieves data from IoT sensors using the HTTP protocol over the internet. The collected data is stored in the ThingSpeak cloud database for ease of data backup, monitoring and analysis. The data collection and uploading cycle will run continuously. Details specifications of the GW unit and the e-PADI power management system is summarised in Annex B.

5.5 e-PADI monitoring dashboard

The e-PADI monitoring dashboard enables the measured data to be viewed by farmers. Any parameter that falls beyond the threshold will trigger an alert to the screen notifications on the dashboard system called the e-PADI dashboard. This application provides information available in the ThingSpeak database, thus allows the stored data in the cloud database to be monitored and analysed remotely.

The android-based user application unit can be installed on a smartphone, tablet or computer. The system is capable to monitor the status of the paddy development beginning from soil preparation, vegetative stage until the harvesting stage. The monitoring period of paddy development takes approximately 120 days, depending on types of paddy seeds. During these stages, an advisory notification will also be generated whenever required for farmers to perform immediate actions. This interactive and real-time user application software enables more efficient paddy management by farmers.

6. Result analysis

6.1 Sensor nodes and user application

Figure 8 shows the e-PADI dashboard with all variables captured from sensor node 1. The sensor node 1 displayed 9 different important variables including its advisory notifications.

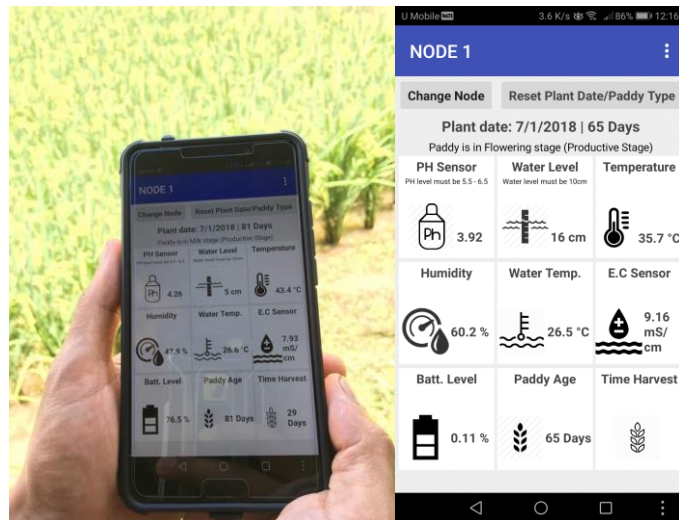

Figure 8. e-PADI dashboard view from user smartphone

The system allows the user to set or reset the paddy plantation date, thus enabling the user to know precisely the age of paddy and the best date to harvest it. This system is also able to indicate the stages of paddy development based on the set plantation date. To view other measured variables in other nodes, the system allows the user to change to other nodes easily.

The advisory notification from the e-PADI dashboard will trigger the farmer on the recommended parameter. For example, 65 days paddy requires a 10 cm water level for paddy productive stage. This enables farmers to adjust the water level in the paddy field accordingly.

6.2 GW unit

The GW unit function is to collect measured paddy variables from sensor nodes via Long Range Wide Area Network (LoRaWAN) in the sensor node. Then, it converts and packed the data into string data type before transmitting the data to the host i.e. the ThingSpeak using HTTP.

Figure 9 shows the GW successfully uploading data to a database and spreadsheet. Once all sensor data have been recorded in the spreadsheet, the graph of sensor data can be generated and viewed from the user application software.



Figure 9. Sensor data status displayed on the GW

6.3 Continuous analysis mode

Figure 10 shows the results of the soil acidity in the testing site recorded from sensor nodes 1 until 10. From the graph plot, it shows that the average pH value is 5.81 with the minimum and maximum of 5.5 and 8.1. Based on the generated e-PADI advisory report, pH above 5.5 is acceptable and no further action is required by the farmer. However, continuous monitoring is still required to ensure paddy productivity.

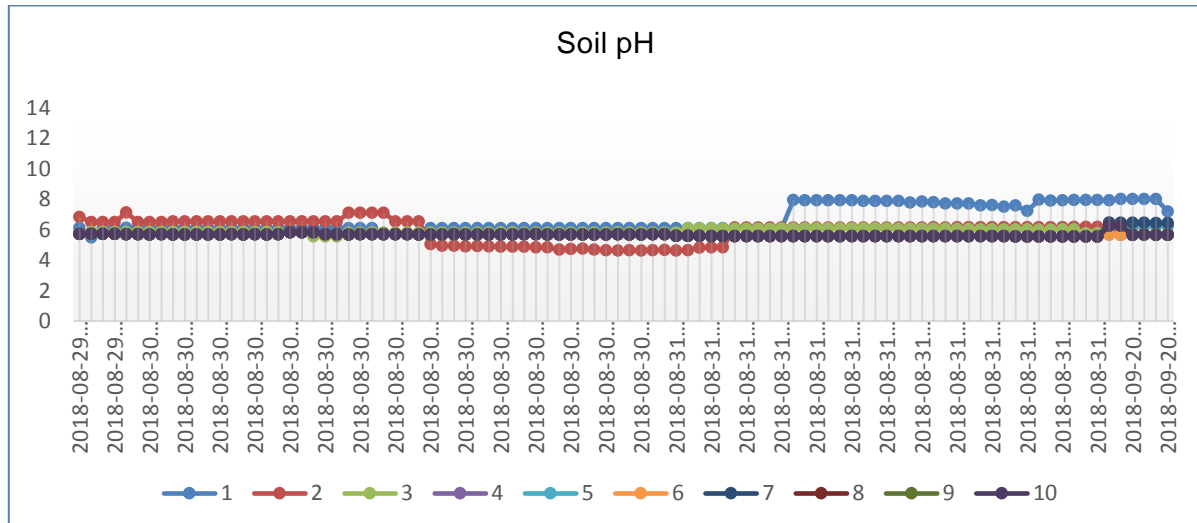

Figure 10. Soil pH measurement on nodes 1 until 10

The measured water level in the testing site as shown in Figure 11 has demonstrated a variety of water levels. The graph plot indicates that the average water level is 6.57 cm with a minimum and maximum of 4 cm and 10 cm.

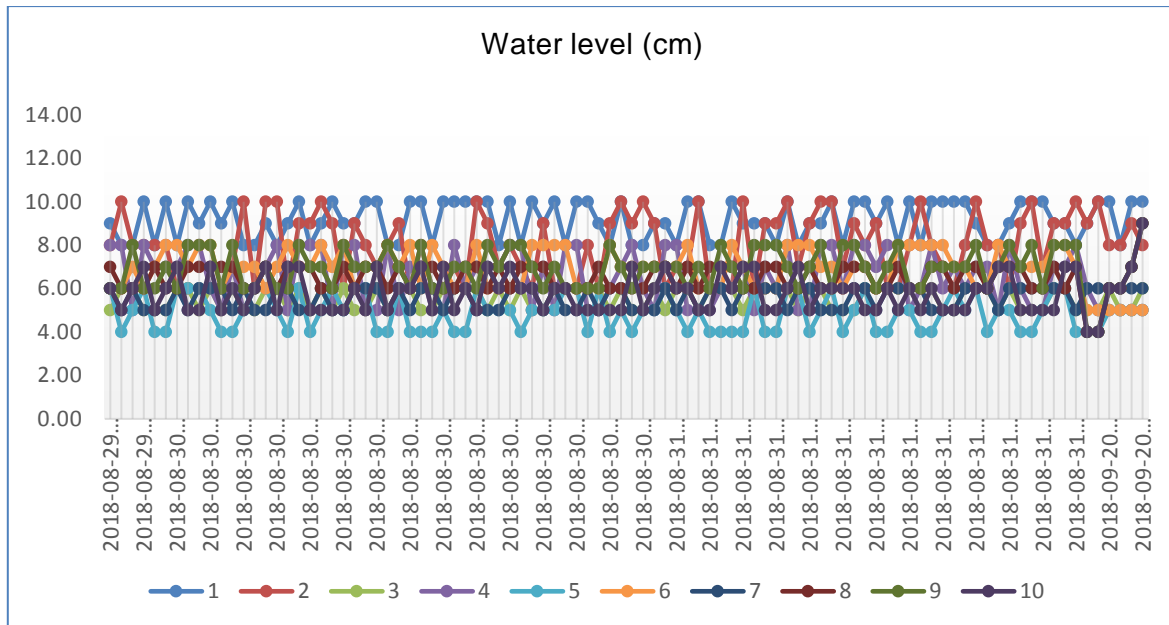

Figure 11. Water level measurement on nodes 1 until 10

The variety of water level readings are due to many factors. Based on the site observation, it is found that the 2 main factors which influence the reading are as follows:

- a) the windy and open space paddy field cause fluctuation of water; and
- b) uneven surface of the land in the paddy field.

This analysis proved that there is a need for land levelling for the next cycle of paddy cultivation.

7. Conclusion

The e-PADI system able to monitor the paddy developments continuously and giving the farmers an advisory system to help them in managing the farm effectively. The e-PADI consist of IoT based system that has been developed to enable the enhancement of the existing conventional system. The main component of this e-PADI system is the sensors that able to sense the crucial paddy parameters. These paddy parameter data are stored in the cloud server for the ease of data back-up, monitoring and data retrieval via user smartphones, tablets and computers. These data will be analysed to provide guidance/advisory information to the farmers during the paddy development stages. Thus, the e-PADI system enables farmers to perform well-planned paddy management includes managing the amount of water and fertilizers in the paddy field according to guidelines by authorities and consequently gain better paddy productivity. The features that exist in the e-PADI system has successfully met the objectives of this project.

Annex A
(informative)

List of sensors

The sensors and their specifications used in e-PADI are described in Table A.1.

Table A.1. List of sensors and its specifications





Sensor	Description	Specification
<p>Soil pH</p> 	<p>The industry standard soil pH sensor measures soil pH in the paddy field. The good soil pH for paddy is 5.5 - 6.5. Advisory notifications will pop out if the measured pH is out of the specified range.</p>	<ul style="list-style-type: none"> • Input voltage: + 5.00 Vdc • Measuring Range: 0 pH ~ 10 pH °C • Accuracy: <math>\pm 0.2</math> pH (25 °C) • Operating Temperature: 5 °C ~ 60 °C • Interface: BNC • Output Signal: 0 V ~ 4.0 V
<p>Water Temperature (DS18B20)</p> 	<p>The DS18B20 temperature sensor uses one wire communication to communicate with microcontroller and each sensor has their specific address to communicate with the microcontroller. The water temperature affects the chemical and biological characteristic of the paddy plantation especially the level of dissolved oxygen in the paddy field.</p>	<ul style="list-style-type: none"> • Input voltage: 3.0 Vdc to 5.5 Vdc power/data • Accuracy: ± 0.5 °C (from - 10 °C to + 85 °C) • Measured temperature range: - 55 °C to 125 °C • Interface: 1 wire • Resolution: 9 bit to 12 bit selectable
<p>Light Intensity (BH1750)</p> 	<p>The BH1750 light intensity sensor measures the level of light reflection in the paddy field. It ensures the charging cycle of the solar panel occurs correctly. The light intensity sensor also determines the change of UV level in the paddy field.</p>	<ul style="list-style-type: none"> • Input voltage: + 3 Vdc to 5 Vdc • Interface: I²C
<p>Water Level (SN-JSN-SR04T)</p> 	<p>This waterproof ultrasonic range finder module measures water level in the paddy field. Different paddy stages require different water level.</p>	<ul style="list-style-type: none"> • Input voltage: 3.3 Vdc to 5 Vdc • Acoustic emission frequency: 40 kHz • Farthest distance: 4.5 m • Resolution: 0.5 cm • Angle: less than 50 °C • Working temperature: - 10°C ~ 70 °C

Table A.1. List of sensors and its specifications (continued)

Sensor	Description	Specification
<p>Temperature & Humidity (Si7021)</p>  <p>The image shows a blue PCB sensor module with a white Si7021 chip. It has two circular ports at the top for air flow. Labels include 'Si7021 RH%', 'UIN', 'GND', 'SDA', '3Uo', and 'SCL'.</p>	<p>This sensor measures the environment temperature of the paddy field. It ensures the e-PADI system works in the best working conditions. The chip comprises of a monolithic CMOS IC integrated, analogue to digital converter, signal processing and calibration data.</p>	<ul style="list-style-type: none"> • Input voltage: 1.9 Vdc to 3.6 Vdc • Interface: I²C • Working temperature: - 40 °C to 125 °C • Power consumption (active): 150 μA • Accuracy: ± 0.4 °C/± 3 % relative humidity
<p>Battery level</p>  <p>The image shows a black PCB module with a yellow battery. It has several pins and labels: '3.7V Li Battery Fuel Gauge V1.0', 'Gravity', 'BAT IN', '3.7V', 'ALR', 'GND', and 'IIC'.</p>	<p>This 3.7V Li Battery Fuel Gauge measures the battery level of Lithium Polymer (Li-polymer) battery. The main power supply of the e-PADI system is supplied from the Li-polymer battery. Hence continuous voltage supply of the unit is important.</p>	<ul style="list-style-type: none"> • Input voltage: 3.3 Vdc ~ 6.0 Vdc • Battery input voltage (BAT IN): 2.5 Vdc ~ 4.2 Vdc • Battery type (BAT IN): 3.7 V Li-polymer/Li-ion battery • Operating current: 50 μA • Interface: I²C (logic level: 0 Vdc - 3.3 Vdc)

Annex B
(informative)

List of gateways

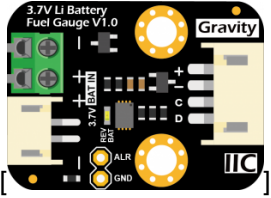
The GW and their specifications used in e-PADI are described in Table B.1.

Table B.1. List of GWs and its specifications



GW	Description	Specification
<p>Main Controller (ATmega328P)</p> 	<p>This Arduino Nano with ATmega328P is used in each e-PADI sensor node. It also used the e-PADI GW system. In the GW system, it collects data from sensor nodes and passes the data to the client microcontroller (node MCU).</p>	<ul style="list-style-type: none"> a) Microcontroller: ATmega328P b) Operating voltage: 5 V c) Flash memory: 32 kb of which 2 kb used by bootloader d) SRAM: 2 kb e) Clock speed:16 MHz f) Analog IN pins: 8 g) EEPROM: 1 kb h) Input voltage: 7 Vdc - 12 Vdc i) Digital I/O pins: 22 (6 of which are PWM) j) PWM output: 6 k) Power consumption: 19 mA
<p>Client microcontroller (ESP8266 WiFi SoC)</p> 	<p>NodeMCU is an open source IoT platform. It includes ESP firmware which runs on the ESP8266 WiFi SoC from the microcontroller systems and hardware which is based on the ESP-12 module.</p>	<ul style="list-style-type: none"> a) Operating voltage: 3.3 Vdc (can be USB powered). b) Microcontroller: 32-bit c) CPU: ESP8266 (LX106), 80 MHz d) GPIO pins: 16 e) Memory: 128 kb f) Operating system: XTOS g) Storage: 4 Mb h) Serial data communication: data sensor 1-8 in string format i) Digital signal: 2-bit (WiFi connection status (0-not connected, 1-connected), data transmission status (0-busy, 1-idle)) j) Built-in PCB antenna on the ESP-12N chip.

Table B.1. List of GWs and its specifications

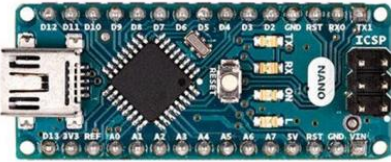
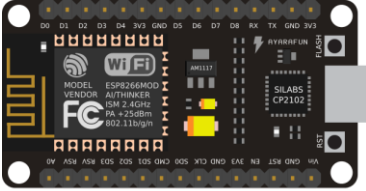

Gateway	Description	Specification
<p style="text-align: center;">LoRaWAN (E32-TTL-1W/915T30D)</p>  <p>The image shows a LoRaWAN module with a gold SMA connector. The label includes the model number E32 915T30D, the manufacturer EBYTE, a QR code, a RoHS logo, and technical details: SN: 18011800001, Made in China, Manufacturer: EBYTE, and FCC ID: 2ALPH-E32.</p>	<p>LoRa (Long Range) is a modulation technique that enables the long-range transfer of information with a low transfer rate.</p>	<ul style="list-style-type: none"> a) Interface: UART b) Power :30 dBm c) Distance: 8000 m d) Operating frequency: 915 MHz (900 MHz – 931 MHz) e) Transmitting power: 1.0 W f) Operating voltage: 3.3 Vdc - 5.0 Vdc g) Baud Rate: 9600
<p style="text-align: center;">MiFi (D-LINK DWR-710 HSPA)</p>  <p>The image shows a white, portable MiFi USB Modem with a sliding cover. The device is labeled with the D-Link logo and model number DWR-710.</p>	<p>This portable MiFi USB Modem establishes 3G communication and connects the e-PADI client microcontroller to the cloud database. The e-PADI system may also be connected to other available WiFi connection.</p>	<ul style="list-style-type: none"> h) Coverage: 3G

Annex C
(informative)

List of power management

The power management and their specifications used in e-PADI are described in Table C.1.

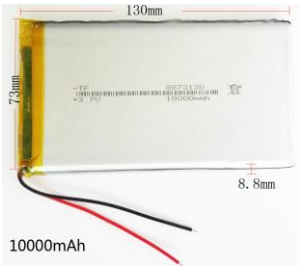
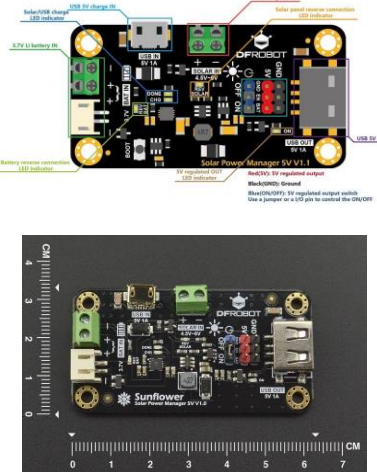
Table C.1. List of power management and its specifications

GW	Description	Specification
<p>Lithium Polymer (LiPo) Battery</p> 	<p>This 3.7V Li Battery supplies input voltage to the e-PADI system.</p>	<ul style="list-style-type: none"> a) Operating Voltage: 3.7 Vdc b) Capacity: 10 000 mAh c) Type: Li-polymer
<p>Solar Power Manager (CN3065)</p> 	<p>The solar power manager manages the power supply system for the e-PADI sensor nodes. This high-efficiency embedded solar power management module support IoT and renewable energy projects.</p>	<ul style="list-style-type: none"> a) Solar input voltage (SOLAR IN): 4.5 Vdc ~ 6 Vdc b) Battery input (BAT IN): 3.7 V single cell Li-polymer/Li-ion battery c) Charge current (USB/SOLAR IN): 900 mA Max trickle charging, constant current, constant voltage 3 phases charging d) Charging cut-off voltage (USB/SOLAR IN): 4.2 V ± 1 % e) USB IN voltage: 5 V f) Regulated power supply: 5 V 1 A g) Regulated power supply efficiency (3.7 V battery IN) h) USB/solar charge efficiency: 73 %/3.7 V 900 mA BAT IN i) Operation temperature: 40 ° C ~ 85 ° C
<p>Solar Cell</p> 	<p>The solar panel charges the e-PADI system whenever the battery level dropped below 40 %.</p>	<ul style="list-style-type: none"> a) Solar Panel with USB Type 5 V 5 W (1 A) b) Dimension: 22.5 cm x 19.5 cm c) Thickness: 1.8 cm d) Type: Monocrystalline

References

- [1] *An overview of global rice production, supply, trade, and consumption*, The Sax Institute, Ultimo, Australia, Muthayya S1, Sugimoto JD, Montgomery S, Maberly GF and Ann N Y Acad Sci, 2014.
- [2] *E-kakashi project, an agri sensor network using ad hoc network technology*, in *SICE Annual Conference (SICE)*, N. Yamaguchi, Y. Sakai, T. Shiraishi, S. Onishi, and T. Kowata, 2011.
- [3] *Agro-sense: precision agriculture using sensor-based wireless mesh networks*, in *Innovations in NGN: Future Network and Services*, First ITU-T Kaleidoscope Academic Conference 2008, A.D. Siuli Roy and Sanghamitra Bandyopadhyay, 2008, pp. 383-388.
- [4] *An architecture for the agricultural machinery intelligent scheduling in cross-regional work based on cloud computing and internet of things*, in *Computer and Computing Technologies in Agriculture IV*, S. Zhiguo, X. Hui, and W. Wensheng, 2010, pp. 9-15.
- [5] *Application of the Internet of Things Technology in Precision Agriculture Irrigation Systems*, in *Computer Science & Service System (CSSS)*, 2012 International Conference, S. Li, pp. 1009-1013.
- [6] *Automation of Agriculture Support Systems using Wisekar: Case study of a crop-disease advisory service*, *Computers and electronics in agriculture*, S. Sarangi, J. Umadikar, and S. Kar, 2016 vol. 122, pp. 200-210.
- [7] *Application of Remote Sensors in Mapping Rice Area and Forecasting Its Production: A Review*, Mostafa K. Mosleh, Quazi K. Hassan and Ehsan H. Chowdhury, *Sensors* 2015, 15(1), 769-791.
- [8] *In Science of the Rice Plant, Physiology*, Food and Agriculture Policy Research Center, Tokyo Japan, Matsuo, Kumazawa, Ishii, Ishihara, Hirata, Vol. 2. 1995.
- [9] *Leaf color chart for managing nitrogen fertilizer in lowland rice in Bangladesh*, Alam MM, Ladha JK, Rahman Khan S, Foyjunnessa, Harun-ur-Rashid, Khan AH, Buresh R.J. and Agron J., 2005, 97:949–959.
- [10] *Growing at a slower pace, world population is expected to reach 9.7 billion in 2050 and could peak at nearly 11 billion around 2100.* (2019, June 17). Retrieved from <https://www.un.org/sustainabledevelopment/blog/2019/06/growing-at-a-slower-pace-world-population-is-expected-to-reach-9-7-billion-in-2050-and-could-peak-at-nearly-11-billion-around-2100-un-report/>

Publication of:



Malaysian Technical Standards Forum Bhd (MTSFB)

Malaysian Communications and Multimedia Commission (MCMC)
Off Persiaran Multimedia, Jalan Impact, Cyber 6
63000 Cyberjaya, Selangor Darul Ehsan
Tel: (+603) 8320 0300
Fax: (+603) 8322 0115
Website: www.mtsfb.org.my

In collaboration with



Malaysian Communications and Multimedia Commission (MCMC)

MCMC Tower 1
Jalan Impact, Cyber 6, 63000 Cyberjaya
Selangor Darul Ehsan
Tel: (+603) 8688 8000
Fax: (+603) 8688 1000
Website: www.mcmc.gov.my